

GLOBALSAT GPS+BDS Engine Board

Hardware Data Sheet

Product No : MT-5365B

Version 1.0



GlobalSat WorldCom Corporation

16F., No. 186, Jian-Yi Road, Chung-Ho City, Taipei
Hsien 235, Taiwan

Tel: 886-2-8226-3799 Fax: 886-2-8226-3899

E-mail : service@globalsat.com.tw

Website: www.globalsat.com.tw

Issue Date	APPR	CHECK	PREPARE
2013/04/17	Ray		Mason

Product Description

Product Description

MT-5365B is a compact, high performance, and low power consumption GPS+BDS engine board. The chipset is powered by MediaTek, it can provide you with superior sensitivity and performance even in urban canyon and dense foliage environment. The miniature size makes the module easy and the best choice to integrate into portable applications such as DSC, cellular phone, PMP, and gaming devices. MT-5365B is suitable for the following applications:

- Automotive navigation
- Personal positioning
- Fleet management
- Mobile phone navigation
- Marine navigation

Product Features

- MediaTek high sensitivity solution
- Support 33 tracking / 99 acquisition-channel GPS/BDS receiver
- Very high sensitivity (Tracking Sensitivity: -165dBm)
- Extremely fast TTFF (Time To First Fix) at low signal level
- Support UART(bidirectional transmission) interface
- Support Serial port NMEA output.
- Built-in LNA
- Compact size (22.4mm x 17.0mm x 3.0mm) suitable for space-sensitive application
- One size component, easy to mount on another PCB board
- Support NMEA 0183 V4.0 (GGA, GSA, GSV, RMC, VTG, GLL, ZDA)
- Supports WASS/EGNOS/MSAS/GAGAN (depends on firmware setting)

Product Pin Description

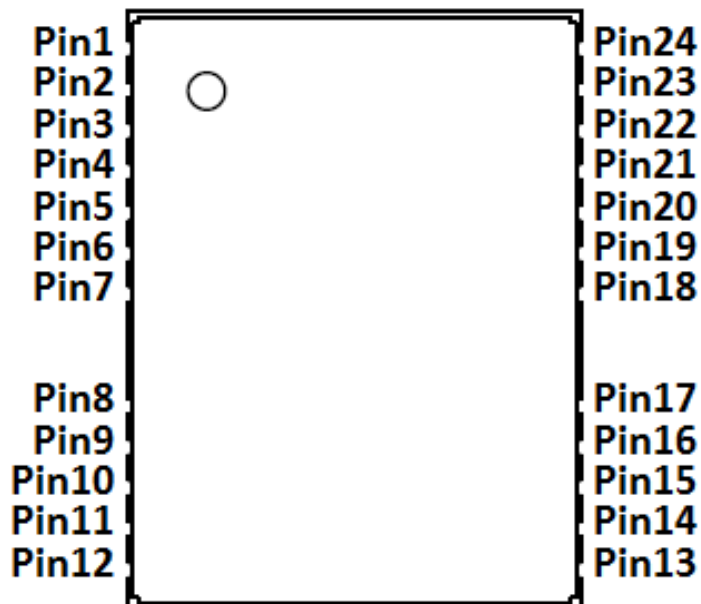

PIN Number(s)	Name	Type	Description	Note
3	TIMEPULSE	O	This pin provides one pulse-per-second output from the board, which is synchronized to GPS time. If do not use it, Just NC.	
5	WAKE_UP	O	MT-5365B hardware standby function, that is edge-trigger type, falling to enter standby mode, and raising to normal mode	
9	VCC_RF	O	VCC_RF can supply active antenna bias voltage. This pin will supply active antenna power and output voltage referred VCC. If do not use it, just NC.	
10,12,13,24	GND	P	Ground	
11	RF_IN	I	This pin receives signal of GPS/BDS analog via external antenna. It has to be a controlled impedance trace at 50ohm. Do not have RF traces closed the other signal path and routing it on the top layer. Keep the RF traces as short as possible.	
20	TXD	O	This is the main transmits channel for outputting navigation and measurement data to user's navigation software or user written software. Baud rate based on firmware setting, Output TTL level 2.8V.	

21	RXD	I	This is the main receive channel for receiving software commands to the engine board from MTK software or from user written software. Baud rate based on firmware setting.
22	VBAT	P	This is the battery backup power input for the SRAM and RTC when main power is off. Without the external backup battery, MT-5365B will always execute a cold start after turning on. To achieve the faster start-up offered by a hot or warm start, a battery backup must be connected. The battery voltage should be between 2.0V and 4.3V.
23	VCC	P	This is the main power supply to the engine board. (3.3Vdc to 6Vdc)
1,2,4,6,7,8,14, 15,16,17,18,19	NC		MT-5365B reserved pin, just NC.

Electrical Specification

Absolute Maximums Ratings

Parameter	Min.	Typ.	Max.	Conditions	Unit
Power					
Power supply voltage(VCC)	3.3	3.3	6.0		V
Backup battery supply	2.0		4.3		V
VCC_RF output voltage		VCC			
Main power supply Current		25		3.3V	mA
Backup battery supply Current	4.5	5	5.5	3.3V	uA
RF Input					
Input Impedance		50			Ω
Operating Frequency		1.575 1.561			GHz

DC Electrical characteristics

Parameter	Symbol	Min.	Typ.	Max.	Conditions	Units
I/O Low Level Output Voltage	V_{OL}			0.42		V
I/O High Level Output Voltage	V_{OH}	2.38				V
I/O Low Level Input Voltage	V_{IL}	-0.3		0.7		V
I/O High Level Input Voltage	V_{IH}	2.1		3.6		V
TXD Output Voltage	V_{TO}	2.52	2.8	3.08		V
RXD Input Voltage	V_{RI}			3.6		V
High Level Output Current	I_{OH}		2			mA
Low Level Output Current	I_{OL}		2			mA

Environmental Characteristics

Parameter	Min	Typ	Max	Unit
Humidity Range	5		95	% non-condensing
Operation Temperature	-40	25	85	$^{\circ}\text{C}$
Storage Temperature	-40		85	$^{\circ}\text{C}$

Receiver Performance

Sensitivity ¹	Chipset Tracking : Chipset Autonomous acquisition :	-165dBm -148 dBm
Time-To-First-Fix ²	Cold Start – Autonomous	< 35s
	Warm Start – Autonomous	< 35s
	Hot Start – Autonomous	< 1s
Horizontal Position Accuracy ³	Autonomous SBAS	< 3m (2D RMS) <2.0m
Velocity Accuracy ⁴	Speed	< 0.01 m/s
	Heading	< 0.01 degrees
Reacquisition	0.1 second, average	
NMEA Update Rate	Output data format based on firmware setting	
Maximum Altitude	< 18,000 meter	
Maximum Velocity	< 515 meter/ second	
Maximum Acceleration	< 4G	

Package Dimensions

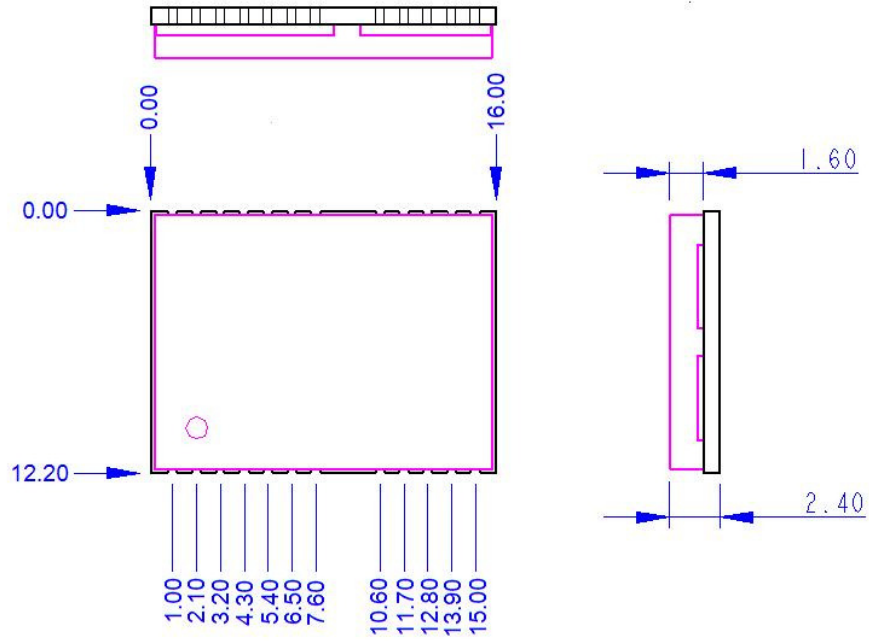

Type	24-pin stamp holes
Dimensions	16.0 mm * 12.2 mm * 2.4 mm ±0.2mm

Application

Application circuit with passive antenna

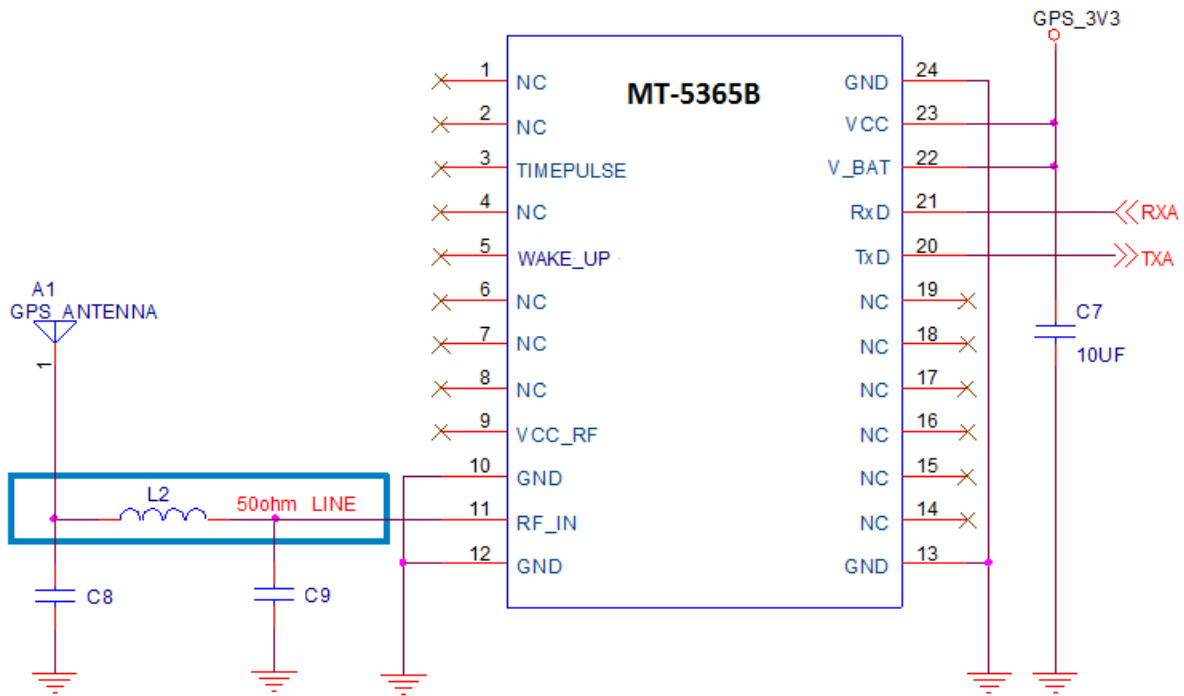

Application circuit with active antenna

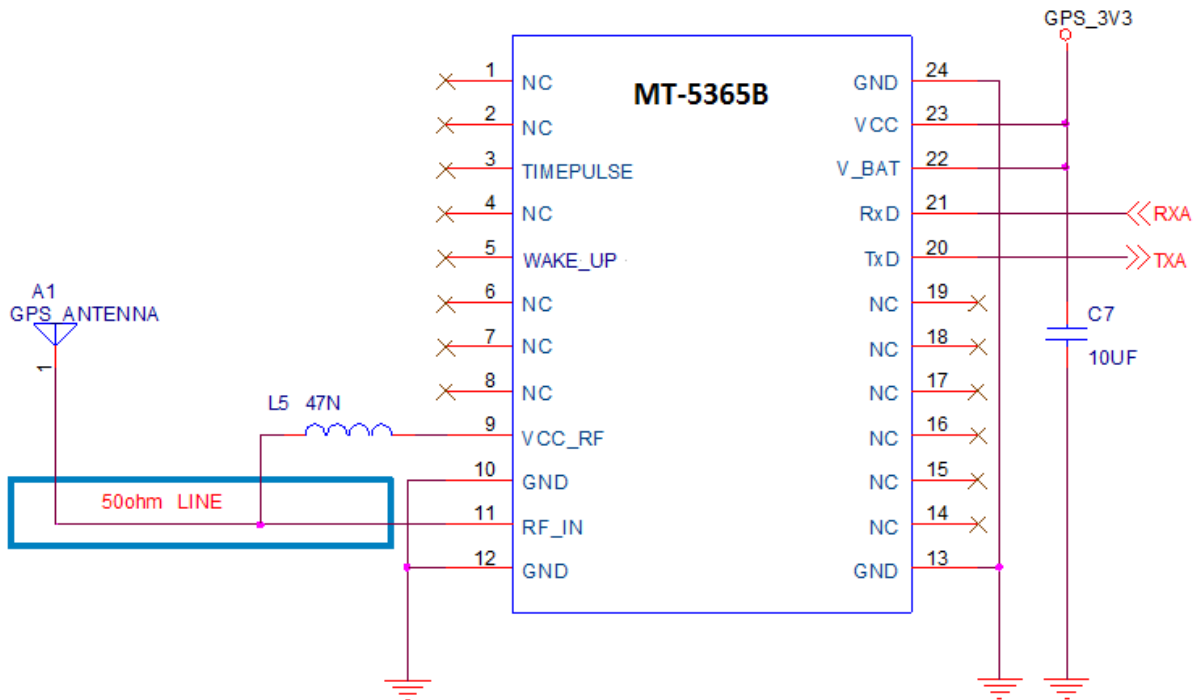

GPS/BDS Active Antenna Specifications (Recommendation)

Frequency:	1575.42 + 2MHz 1561.098 + 2MHz	Amplifier Gain:	18~22dB Typical
Axial Ratio:	3 dB Typical	Output VSWR:	2.0 Max.
Output Impedance:	50Ω	Noise Figure:	2.0 dB Max
Polarization:	RHCP	Antenna Input Voltage:	2.85V (Typ.)

NOTE:

1. VBAT: This is the battery backup power input for the SRAM and RTC when main power is removed. VBAT is 2V ~ 4.3V.
2. VCC_RF: MT-5365B provides power to external active antenna, this voltage level refer VCC.

Recommended Layout PAD

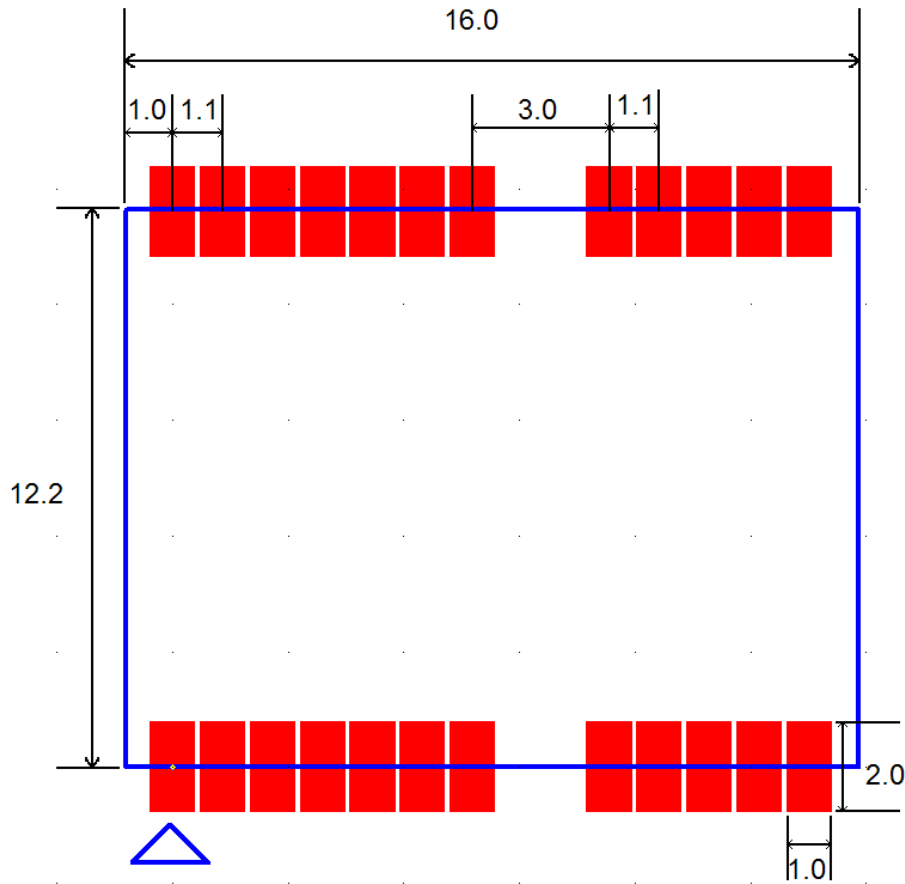

Unit: mm
Tolerance: 0.1mm

PCB Layout Recommend

Do not routing the other signal or power trace under the engine board.

RF:

This pin receives signal of GPS/BDS analog via external active antenna .It has to be a controlled impedance trace at 50ohm.

Do not place the RF traces close to the other signal path and not routing it on the top layer.

Keep the RF traces as short as possible.

Antenna:

Keep the active antenna on the top of your system and confirm the antenna radiation pattern 、 axial ratio 、 power gain 、 noise figure 、 VSWR are correct when you Setup the antenna in your case.

Recommended Reflow Profile:

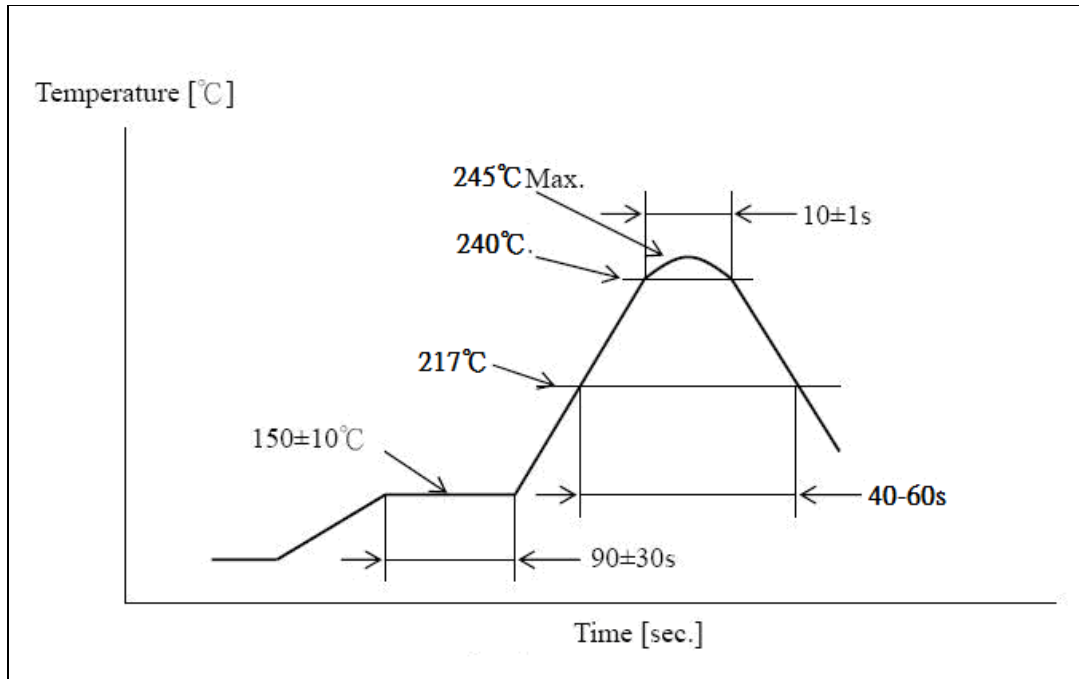

Pre heating temperature: 150±10[°C] Pre heating time: 90±30[sec.]

Heating temperature: 240±5[°C] Heating time: 10±1[sec.]

Peak temperature must not exceed 245°C and the duration of over 217°C should be 40 - 60 Seconds.

Appendix

Label Artwork

A: Brand: GLOBALSAT
B: MODULE Model: MT-5365B
B-1:
G = GLONASS
B = BDS
C = Single Type
C: CHIP Type: MTK
D: Bar code
E: Serial Number:



Product NO (HEX)

Place of origin, **T= Taiwan, **C=China

Reversion history

Reversion	Date	Name	Status / Comments
V1.0	2013/4/17	Mason	Initial Version (PCB Version: MT-5365 V1.2)