

GLOBALSAT GPS+GLONASS Engine Board

Hardware Data Sheet

Product No : MT-5608G

Version 1.0



GlobalSat WorldCom Corporation

16F., No. 186, Jian-Yi Road, Chung-Ho City, Taipei

Hsien 235, Taiwan

Tel: 886-2-8226-3799 Fax: 886-2-8226-3899

E-mail : service@globalsat.com.tw

Website: www.globalsat.com.tw

Issue Date	APPR	CHECK	PREPARE
2014/3/4	Ray		Mason

Product Description

Product Description

MT-5608G is a compact, high performance, and low power consumption GPS+GLONASS engine board. The chipset is powered by MediaTek, it can provide you with superior sensitivity and performance even in urban canyon and dense foliage environment. The miniature size makes the module easy and the best choice to integrate into portable applications such as DSC, cellular phone, PMP, and gaming devices. MT-5608G is suitable for the following applications:

- Automotive navigation
- Personal positioning
- Fleet management
- Mobile phone navigation
- Marine navigation
- Camera Positioning
- Health and fitness device
- Tablet computer

Product Features

- MediaTek high sensitivity solution
- Support 99 search channels and 33 simultaneous tracking channels.
- Very high sensitivity (Tracking Sensitivity: -165dBm)
- Extremely fast TTFF (Time To First Fix) at low signal level
- Support UART(bidirectional transmission) interface
- Built-in LNA
- Compact size (8.8mm x 6.5mm x 2.4mm) suitable for space-sensitive application
- One size component, easy to mount on another PCB board
- Support NMEA 0183 V4.0 (GGA, GSA, GSV, RMC, VTG, GLL, ZDA)
- Supports WASS/EGNOS/MSAS/GAGAN (depends on firmware setting)

Note: Features mentioned above are available depending on firmware versions. Please contact us first to specify which features you will require, before purchase

Product Pin Description

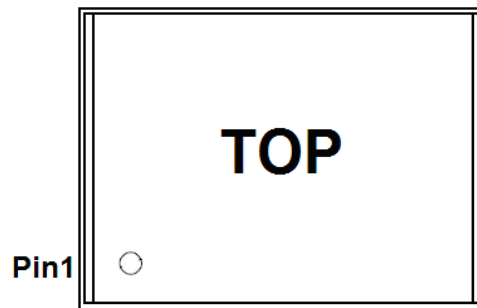
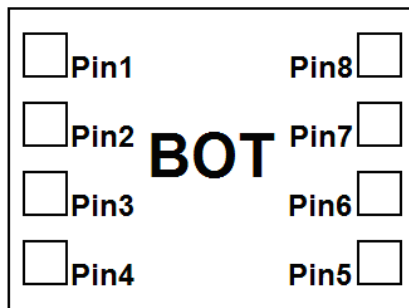
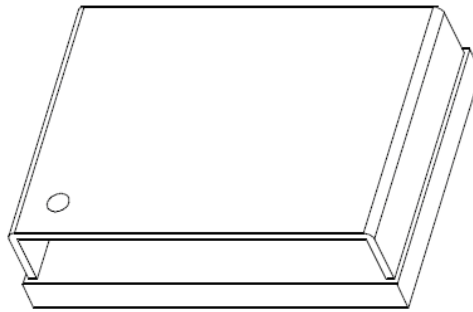

PIN Number(s)	Name	Type	Description	Note
1	TIMEMARK	O	This pin provides one pulse-per-second output from the board (depends on firmware setting), which is synchronized to GPS time. If do not use it, Just NC.	
2	RESERVED		MT-5608B reserved pin, just NC.	
3	GND	P	Ground	
4	RF_IN	I	This pin receives signal of GPS/GLONASS analog via external antenna. It has to be a controlled impedance trace at 50ohm. Do not have RF traces closed the other signal path and routing it on the top layer. Keep the RF traces as short as possible.	
5	TXD	O	This is the main transmits channel for outputting navigation and measurement data to user's navigation software or user written software. Baud rate depends on firmware setting, Output TTL level 2.8V.	

6	RXD	I	This is the main receive channel for receiving software commands to the engine board from MTK software or from user written software. Baud rate depends on firmware setting.	
7	VBAT	P	This is the power input for the SRAM and RTC. To achieve the faster start-up offered by a hot or warm start, a backup power must be connected. The power voltage should be between 2.5V and 4.3V.	
8	VCC	P	This is the main power supply to the engine board. (3.1Vdc to 4.3Vdc)	

Electrical Specification

Absolute Maximums Ratings

Parameter	Min.	Typ.	Max.	Conditions	Unit
Power					
Power supply voltage(VCC)	3.1	3.3	4.3		V
Backup battery supply	2.5		4.3		V
Main power supply Current		34		3.3V, No Fixed	mA
		28		3.3V, Fixed	mA
Backup battery supply Current	5.5	6	6.5	3.3V	uA
RF Input					
Input Impedance		50			Ω
Operating Frequency		1.575			GHz
		1.608			

DC Electrical characteristics

Parameter	Symbol	Min.	Typ.	Max.	Conditions	Units
I/O Low Level Output Voltage	V_{OL}			0.42		V
I/O High Level Output Voltage	V_{OH}	2.38				V
I/O Low Level Input Voltage	V_{IL}	-0.3		0.7		V
I/O High Level Input Voltage	V_{IH}	2.1		3.6		V
TXD Output Voltage	V_{TO}	2.52	2.8	3.08		V
RXD Input Voltage	V_{RI}			3.6		V
High Level Output Current	I_{OH}		2			mA
Low Level Output Current	I_{OL}		2			mA

Environmental Characteristics

Parameter	Min	Typ	Max	Unit
Humidity Range	5		95	% non-condensing
Operation Temperature	-40	25	85	$^{\circ}\text{C}$
Storage Temperature	-40		85	$^{\circ}\text{C}$

Receiver Performance

Sensitivity ¹	Chipset Tracking :	-165dBm
	Chipset Autonomous acquisition :	-148 dBm
Time-To-First-Fix ²	Cold Start – Autonomous	< 35s
	Warm Start – Autonomous	< 35s
	Hot Start – Autonomous	< 1s
Horizontal Position Accuracy ³	Autonomous	< 3m (2D RMS)
	SBAS	< 2.0m
Velocity Accuracy ⁴	Speed	< 0.01 m/s
	Heading	< 0.01 degrees
Reacquisition	0.1 second, average	
NMEA Update Rate	Output data format based on firmware setting	
Maximum Altitude	< 18,000 meter	
Maximum Velocity	< 515 meter/ second	
Maximum Acceleration	< 4G	

Package Dimensions

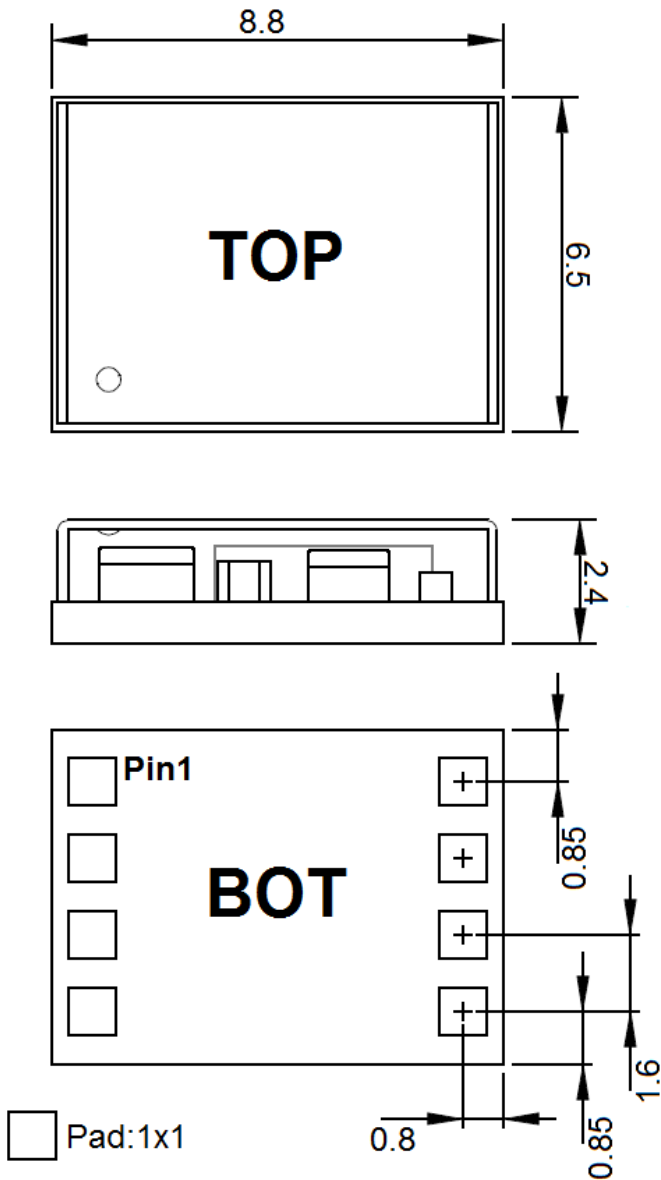

Type	8-pin stamp holes
Dimensions	8.8 mm * 6.5 mm * 2.4 mm ±0.2mm

Application

Application circuit with passive antenna

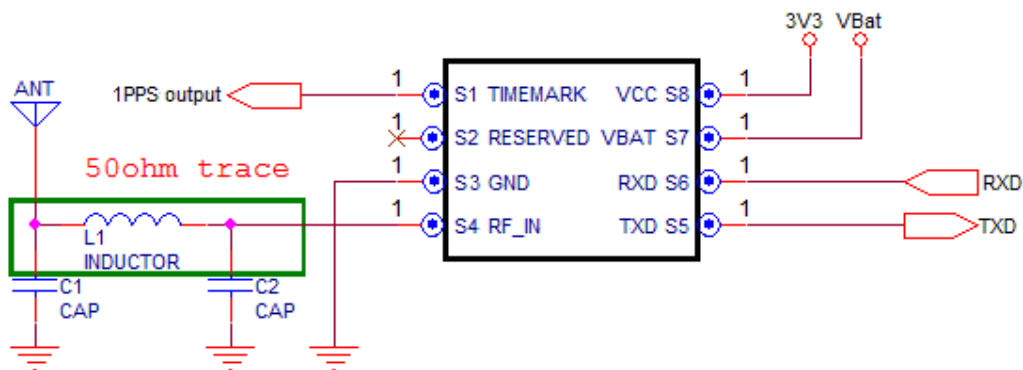

Application circuit with active antenna

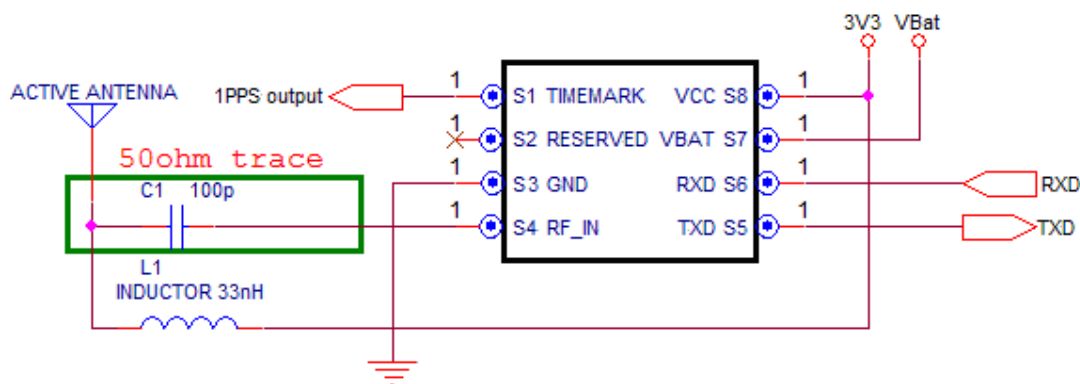

GPS/GLONASS Active Antenna Specifications (Recommendation)

Frequency:	1575.42 + 2MHz 1602MHz~1615MHz	Amplifier Gain:	18~22dB Typical
Axial Ratio:	3 dB Typical	Output VSWR:	2.0 Max.
Output Impedance:	50Ω	Noise Figure:	2.0 dB Max
Polarization:	RHCP	Antenna Input Voltage:	3.0V (Typ.)

Recommended Layout PAD

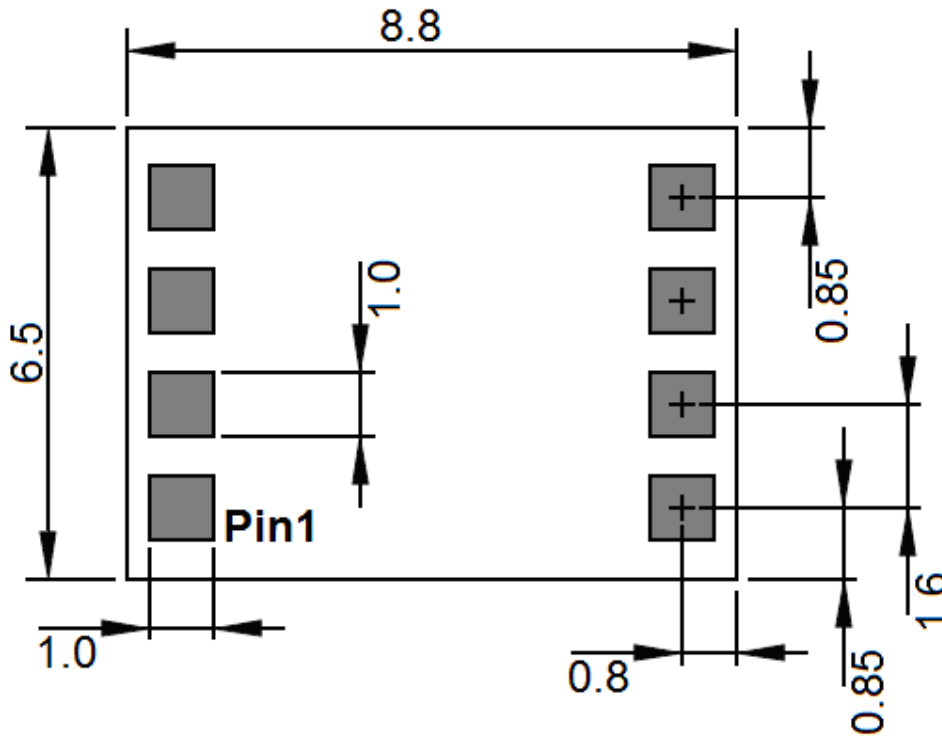

Unit: mm
Tolerance: 0.1mm

PCB Layout Recommend

Do not routing the other signal or power trace under the engine board.

RF:

This pin receives signal of GPS/GLONASS analog via external active antenna .It has to be a controlled impedance trace at 50ohm.

Do not place the RF traces close to the other signal path and not routing it on the top layer.

Keep the RF traces as short as possible.

Antenna:

Keep the active antenna on the top of your system and confirm the antenna radiation pattern 、 axial ratio 、 power gain 、 noise figure 、 VSWR are correct when you Setup the antenna in your case.

Recommended Reflow Profile:

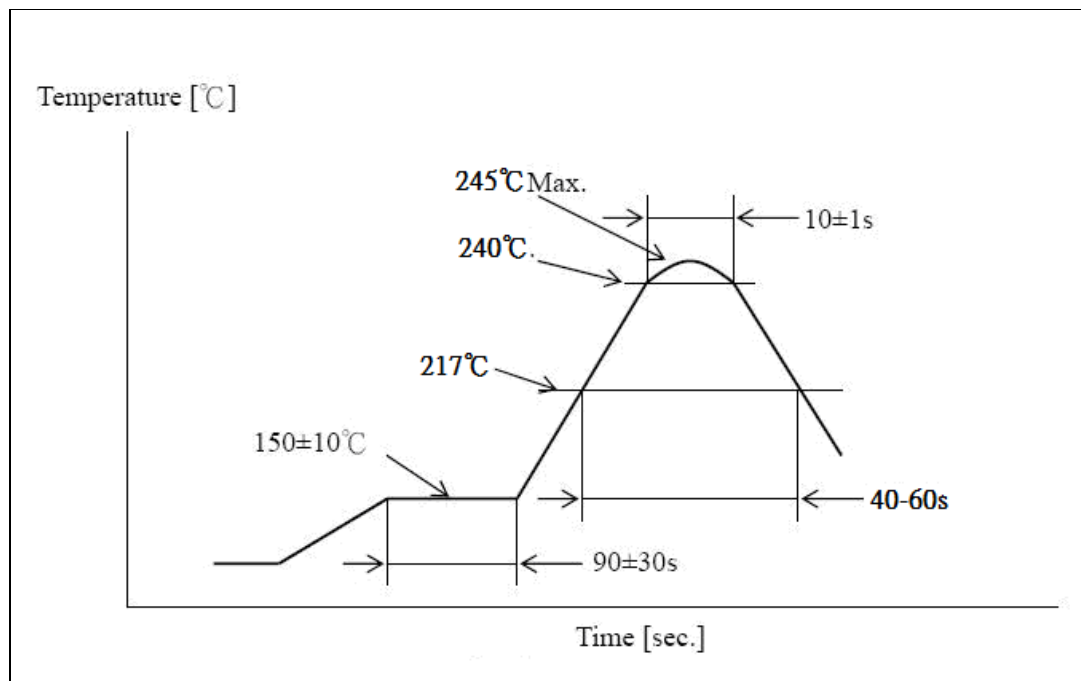

Pre heating temperature: $150 \pm 10 [^\circ\text{C}]$ Pre heating time: $90 \pm 30 [\text{sec.}]$

Heating temperature: $240 \pm 5 [^\circ\text{C}]$ Heating time: $10 \pm 1 [\text{sec.}]$

Peak temperature must not exceed 245°C and the duration of over 217°C should be 40 - 60 Seconds.

Appendix

Label Artwork (TBD)

A: GLOBALSAT

B: Module Info

XX

SX = SiRF

MX = MTK

XG =GPS+GLONASS

XB =GPS+BDS

XC & XS=GPS

XXXX : IC Type & Date code

C: Bar code

D: Serial Number

E: First pin Mark



Reversion history

Reversion	Date	Name	Status / Comments
V1.0	2014/3/4	Mason	Initial Version